

# R&S® ATCMC8

## Air Traffic Control Multicoupler

### Active VHF/UHF multicoupler for 8-port ATC signal distribution



# R&S®ATCMC8

## Air Traffic Control Multicoupler

### At a glance

The R&S®ATCMC8 is a multicoupler specifically designed for ATC receivers from Rohde & Schwarz. It saves space while optimally supporting conventional ATC system installations by means of eight receivers operated in parallel on one antenna.

Alternatively, the R&S®ATCMC16 multicoupler features simultaneous signal distribution to up to 16 receivers.

The multicoupler's integrated, steep-sided filters reliably suppress interference from high-power VHF and TV signals.

To maximize the operational reliability of the ATC receiving system, a single point of failure is avoided in the amplifiers owing to the intelligent switching concept of the R&S®ATCMC multicoupler family. To handle any interruptions in the AC supply voltage, the R&S®ATCMC8 features automatic switchover to the DC input provided for an emergency power supply.

The internal operating state of the R&S®ATCMC8 can be monitored and evaluated by R&S®Series 4200 radios from Rohde & Schwarz via an alarm contact.

- Suppression of adjacent signals from high-power transmitters
- Band-selective in the VHF or UHF ATC frequency range
- 1-to-8 distribution
- Automatic emergency power switchover
- Overvoltage protection
- Floating alarm contact



# R&S®ATCMC8 Air Traffic Control Multicoupler Benefits and key features

## Suppression of adjacent high-power signals

The R&S®ATCMC8's integrated bandpass filtering considerably improves the reception conditions for the connected receivers. Adjacent signals such as high-power FM signals in the VHF band or TV signals in the UHF band are suppressed. To offer optimized filtering for any application, the R&S®ATCMC8 is available as either a VHF or a UHF model. The R&S®ATCMC-B1 option is offered for cases where customized filter frequencies are needed.

## Available as 1-to-8 or 1-to-16 model

In ATC, the parallel operation of eight or 16 receivers on one antenna each is very common. The R&S®ATCMC multicoupler family can easily handle this challenge and is therefore available as either an 8- or 16-port model. To prevent the connected receivers from affecting each other (e.g. due to local oscillators and synthesizers), both models feature high port-to-port isolation.

## Integrated automatic emergency power switchover

The R&S®ATCMC8 is ideal for operation with either AC or DC power. The integrated electronic switchover mechanism automatically detects interruptions in the AC power supply and immediately switches to the DC supply without any signal interruption. Thus, the emergency power supply systems with 24 V DC voltage that are common in ATC can be used.

## Reliable protection against large signals

The integrated protective circuits at the RF input protect the R&S®ATCMC8 against large signals and reliably prevent damage to the connected receivers.

## Remote monitoring through floating alarm contact

Featuring an integrated alarm contact as standard, the R&S®ATCMC multicoupler family offers impressive capabilities for the remote monitoring of the internal operating state. If a malfunction occurs, the R&S®ATCMC8 immediately switches the floating contacts of a relay in order to indicate the modified operating state. All internal supply voltages of the amplifiers are monitored. In conjunction with R&S®Series4200 radios, this alarm contact offers the capability to automatically report the operating state of the R&S®ATCMC8 to the user.



# Specifications

R&S®ATCMC8 VHF		
Frequency range		112 MHz to 144 MHz
Impedance	input/output	50 Ω
RF input	1 ×	N female
VSWR	input	<1.5:1, typ. 1.2:1
FM band suppression	7-pin elliptical highpass filter referenced to 127 MHz	<-25 dB for f < 103 MHz
UHF TV band suppression	3-pin Chebyshev lowpass filter referenced to 127 MHz	<-30 dB for 470 MHz < f < 1 GHz
Max. input power		+15 dBm
RF outputs	8 ×	N female
VSWR	output	<1.5:1, typ. 1.2:1
1 dB compression		>+15 dBm, typ. +19 dBm
Decoupling between two outputs		>27 dB, typ. 34 dB
Intermodulation suppression IP3		>+33 dBm, typ. +36 dBm
Signal amplification		2 dB ±1.5 dB
Noise figure		<7 dB, typ. 4.5 dB
Reverse decoupling		>34 dB, typ. 38 dB

R&S®ATCMC8 UHF		
Frequency range		225 MHz to 400 MHz
Impedance	input/output	50 Ω
RF input	1 ×	N female
VSWR	input	<1.5:1, typ. 1.2:1
VHF band suppression	5-pin Chebyshev highpass filter referenced to 310 MHz	<-17 dB for f < 100 MHz
UHF band V suppression	5-pin Chebyshev lowpass filter referenced to 310 MHz	<-17 dB for 650 MHz < f < 1 GHz
Max. input power		+15 dBm
RF outputs	8 ×	N female
VSWR	output	<1.5:1, typ. 1.2:1
1 dB compression		>+15 dBm, typ. +18 dBm
Decoupling between two outputs	directly adjacent	>23 dB, typ. 26 dB
	not directly adjacent	>23 dB, typ. 30 dB
Intermodulation suppression IP3		>+32 dBm, typ. +35 dBm
Signal amplification		2 dB +2 dB/-1.5 dB
Noise figure		<7 dB, typ. 5 dB
Reverse decoupling		>33 dB, typ. 38 dB

General data R&S®ATCMC8		
Dimensions (W × H × D)		482.6 mm × 43.8 mm × 145 mm (19", 1 HU) 19 in × 1.72 in × 5.71 in
Temperature	operating temperature range	-20 °C to +55 °C
	storage temperature range	-40 °C to +70 °C
Weight		approx. 2.7 kg approx. 5.95 lb
Primary power supply	AC	90 V to 250 V/50 Hz to 60 Hz; IEC connector
Emergency power supply	DC (fully automatic switchover)	23 V to 30 V, typ. 0.3 A
Energy consumption		≤8 W
Alarm contact	maximum switching current	≤1 A
	maximum switching voltage	≤42 V

# Ordering information

Designation	Type	Order No.
<b>VHF frequency range</b>		
Air Traffic Control Multicoupler VHF, 8 outputs	R&S®ATCMC8 VHF	5201.7960.10
Air Traffic Control Multicoupler VHF, 16 outputs	R&S®ATCMC16 VHF	5201.7960.20
<b>UHF frequency range</b>		
Air Traffic Control Multicoupler UHF, 8 outputs	R&S®ATCMC8 UHF	5201.7990.10
Air Traffic Control Multicoupler UHF, 16 outputs	R&S®ATCMC16 UHF	5201.7990.20
<b>Options</b>		
Customized Filter Frequencies	R&S®ATCMC-B1	5201.7954.02

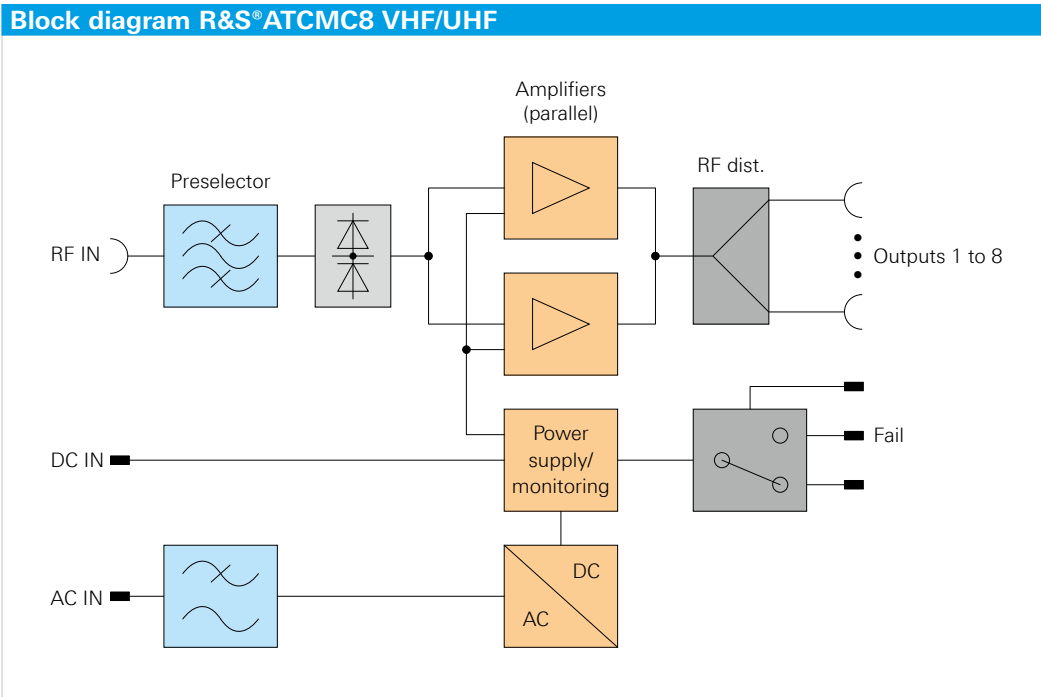

## About Rohde & Schwarz

Rohde & Schwarz is an independent group of companies specializing in electronics. It is a leading supplier of solutions in the fields of test and measurement, broadcasting, radiomonitoring and radiolocation, as well as secure communications. Established 75 years ago, Rohde & Schwarz has a global presence and a dedicated service network in over 70 countries. Company headquarters are in Munich, Germany.

## Service and support

With 24-hour support worldwide and personal service contacts in over 70 countries, Rohde & Schwarz is present around the globe. The company stands for high quality, preventive service, and compliance with delivery schedules – no matter whether the task at hand is calibration or application support.

## Regional contact

Europe, Africa, Middle East

+49 1805 12 42 42 or +49 89 4129 137 74

customersupport@rohde-schwarz.com

North America

+1-888-TEST-RSA (1-888-837-8772)

customer.support@rsa.rohde-schwarz.com

Latin America

+1-410-910-7988

customersupport.la@rohde-schwarz.com

Asia/Pacific

+65 65 13 04 88



More information at  
[www.rohde-schwarz.com](http://www.rohde-schwarz.com)  
(search term: ATCMC/ATCMC8)

## Rohde & Schwarz GmbH & Co. KG

Mühdorfstraße 15 | 81671 München

Phone +498941 290 | Fax +498941 29 12164

[www.rohde-schwarz.com](http://www.rohde-schwarz.com)

R&S® is a registered trademark of Rohde & Schwarz GmbH & Co. KG  
Trade names are trademarks of the owners | Printed in Germany (bb)  
PD 5213.9563.32 | Version 01.00 | February 2008 | R&S®ATCMC8  
Data without tolerance limits is not binding | Subject to change

\*0.14 €/min within German wireline network; rates may vary in other networks (wireline and mobile) and countries.